

# *STE 2*

---

User Manual

# Safety warning

The device meets the requirements of standards valid in the Czech Republic, has undergone live testing and is delivered in operational condition. To maintain the device in this condition, it is necessary to observe the safety and device maintenance requirements set forth below.

*If the device is not used in the manner recommended by the manufacturer, the security offered by the device may be breached!*

*The power socket or point of disconnecting the device from power supply must be freely accessible!*

*The device must not be used in particular if:*

- it is visible damaged
- it does not work properly
- there are loose parts inside the device
- it was exposed to long-term humidity or got wet
- it underwent unqualified repair by unauthorised personnel
- the power adapter or its supply cable are visible damaged
- if the device is used in a manner other than the designated manner, the protection provided by the device may be breached
- the switch or fuse and other power surge protection resources must be part of the overall construction unit

*The manufacturer is liable for the device only if it is powered by the supplied or approved power source.*

Should you have any problems with installation and start-up, you can contact our technical support:

HW group s.r.o.  
<http://www.hw-group.com>  
email: [support@HWg.cz](mailto:support@HWg.cz)

Rumunská 26/122  
Prague, 120 00  
Phone: +420 222 511 918

*Before contacting technical support, prepare the precise model of your device (on the manufacturing label and the firmware version (see below), if you know it.*

# Contents

---

Safety warning	2
Contents	3
STE2 – Basic features	4
Basic features	5
Application	5
Connectors and wiring	6
Recommended connection	7
First start-up	8
WWW interface	10
<i>Home tab</i>	10
<i>General Setup tab</i>	11
<i>Security tab</i>	12
<i>WiFi tab</i>	13
<i>Sensors tab</i>	16
<i>Digital Inputs tab</i>	17
<i>E-mail tab</i>	18
<i>SMS tab</i>	19
<i>Alarms</i>	20
<i>SNMP tab</i>	21
<i>Time tab</i>	23
<i>Portal tab</i>	24
<i>System tab</i>	26
Technical parameters	28
<i>Physical dimensions</i>	29
<i>WiFi Radio</i>	30
<i>WiFi signal strength</i>	30
<i>Impact of device position vis-à-vis the transmitter</i>	31
Supported interfaces	32
<i>Dry contact inputs</i>	32
<i>RJ11 – 1-Wire bus</i>	32
<i>Active / Passive 1-Wire port</i>	33
<i>Sensor Hysteresis</i>	33
Connecting STE2 to the SensDesk portal	34
Using the mobile phone app	39
Firmware upgrade in STE2 units	40

# STE2 – Basic features

*STE2 is a thermometer with an Ethernet and WiFi interface, HTTPS support and option of connection to the SensDesk portal.*

STE2 is a device with HTTPS and SNMP support designated for measuring temperature and humidity from external sensors, with the option of connection to the internet via classic cable or WiFi. If the permitted range of values is exceeded, it allows the sending of an alarm via e-mail, via the SensDesk portal or via SMS. Support of monitoring system is a matter of course and the device is supplied with free HWg-PDMS software to create graphs and export data to MS Excel. The packaging includes a power adapter and temperature sensor.



## Basic features

- Contains classic Ethernet and WiFi – 802.11 b/g/n (2.4 GHz)
- Support of current Ethernet and WiFi operation (for easy configuration)
- 5V or PoE power supply
- Simple installation, supports DHCP
- Built-in WEB server with HTTPS support – no need for any software other than a standard internet browser
- Can be connected to NMS (SNMP MIB)
- Support for simultaneous traffic to both HTTP and HTTPS with the option of disabling one or the other protocol for security reasons
- Sends an e-mail if the temperature is too high / low
- Support of TLS authorisation (GMAIL)
- Password protected
- Supplied with Windows HWg-PDMS software for drawing graphs and exporting data to MS Excel

## Application

### A/C outages

Changes in temperature alert you to outages of the A/C cooling unit.

### Heating monitoring

Remote monitoring of the heating system, alert via e-mail or SMS about the risk of freezing (e-mail-2-SMS).

### Monitoring of provided services

Using the provided HWg-PDMS software, you can easily create reports with temperature graphs at one or several locations. You can have an overview of the quality of outsourced services.

### Fridge and freezer monitoring

Sends an e-mail to alert you of refrigerator outages. Logging of operation and storage conditions.

### Heating optimisation

Cost savings for heating and A/C.

### Food storage

Monitors optimal storage conditions. Protocols for HACCP can be created using the application software.

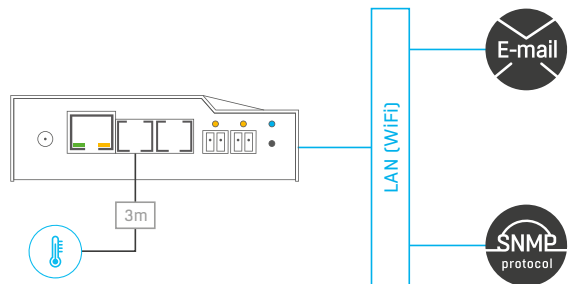

# Connectors and wiring

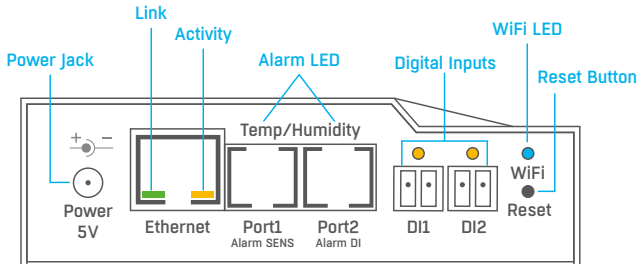

## Description of connectors

- **Ethernet** – Serves for internet connection via cable for operation in a classic computer network and for configuration of operation on WiFi. The connector supports power supply from the computer network via PoE.
- **Temp/Humidity** – Serves to connect up to 3 temperature or humidity sensors. The sensor length may be up to 60 metres in each port.
- **Power** – Connector for 5V power supply in the case of power supply from an external adapter.
- **Digital Inputs** – Serves to connect sensors with digital output.

## LED diodes on the front panel

- **Link** – A green LED signals connectivity to the computer network.
- **Activity** – A yellow flashing LED signals ongoing communication on the cable connection to the computer network.
- **WiFi** – A blue LED signals establishment of a connection to the WiFi connection point. When establishing a connection, it signals the state by flashing.
- **Alarm LED** – Two LEDs hidden in the Port1 and Port2 connectors. Shining LEDs indicate Alarm state.
  - **Alarm SENS** – Shining LEDs signals Alarm state on one of the temperature or humidity sensors.
  - **Alarm DI** – Shining signals Alarm state on one of the digital inputs.

## Description of button function

- **Reset** – serves to restore factory settings on the device.

1. Switch the device off.
2. Press and hold the button.
3. Switch the device on and press the button for another 5 seconds.
4. All the LEDs will gradually light up.
5. Restart the device. Factory settings will be restored.

# Recommended connection

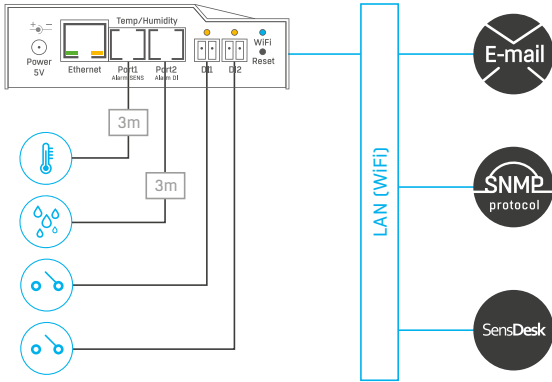

## Sensor connection options:

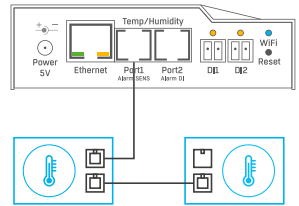
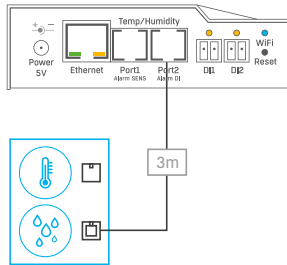
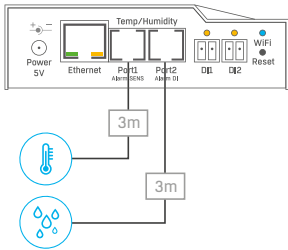

## Smoke sensor connection:

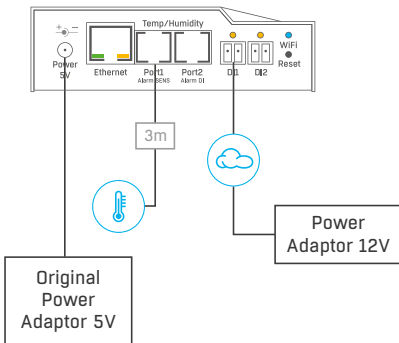

# First start-up

## First step

### 1 Cable connection

- Connect the device to the **Ethernet** (direct cable to the **switch**, crossed to PC).
- Connect the power adapter to the grid and connect it to the device power supply connector.
- The green LED in the **Power & Mode** RJ45 connector will light up.
- If connection to the **Ethernet**, is functional, the **LINK** (yellow) LED should light up shortly afterwards and switch off during data transfer to the Ethernet (Activity signalisation).
- A quickly flashing yellow **LINK** LED signals communication with the DHCP server.

### 2 Setting of the IP address - HWg-Config

The **HWg-Config** program is located in the main director on the enclosed CD (version for Windows and Linux).

The program can be downloaded at [www.HW-group.com](http://www.HW-group.com) Software -> HWg-Config.

- Click on the icon to launch the **HWg-Config** program – the program automatically searches for connected devices.
- Launch the search by clicking on the **Find Devices** icon.
- The program searches for devices in your local network. Click on the MAC address of the device to open the dialogue window for device settings.

MAC	Name	* IP	Device type	Port	Parameters
00:0A:59:00:02:95	Damocles MINI	192.168.100.47	Damocles model MINI	80	TCP setup=Y, DHCP=N
00:0A:59:04:00:5E	SH4 server rack	192.168.100.49	SH4serverrack	80	TCP setup=N, DHCP=N
00:0A:59:02:28:02	HWg-SH4e	192.168.100.57	HWg-SH4e	80	TCP setup=N, DHCP=N
00:0A:59:02:26:7E	HWg-SH4e	192.168.100.58	HWg-SH4e	80	TCP setup=N, DHCP=N
00:0A:59:02:28:82	HWg-SH4e	192.168.100.59	HWg-SH4e	80	TCP setup=N, DHCP=N
00:0A:59:04:00:59	HWg-SH4 test2	192.168.100.60	HWg-SH4test2	80	TCP setup=N, DHCP=N
00:0A:59:04:34:E7	STE2	192.168.100.62	STE2 - Eth	80	TCP setup=N, DHCP=N
00:0A:59:04:00:50	HWg-SH4 Hlavni	192.168.100.63	HWg-SH4Hlavni	80	TCP setup=N, DHCP=N
00:0A:59:04:2F:59	Poseidon2 4002 Vitel	192.168.100.81	Poseidon2 model 4002	80	TCP setup=Y, DHCP=N
00:0A:59:04:05:3C	Poseidon2 4002 Dem	192.168.100.90	Poseidon2 model 4002	80	TCP setup=Y, DHCP=N
00:0A:59:04:0C:30		192.160.100.141	I/O Controller 2	23	TCP setup=Y, TEA=N
00:0A:59:04:0F:48		192.168.100.142	I/O Controller 2	23	TCP setup=Y, TEA=N
00:0A:59:04:33:90	STE2	192.160.200.2	STE2 - Eth	80	TCP setup=N, DHCP=N
00:0A:59:04:35:21	STE2	192.168.200.5	STE2 - Eth	80	TCP setup=N, DHCP=N
00:0A:59:04:35:20	STE2	192.168.200.6	STE2 - Eth	80	TCP setup=N, DHCP=N
00:0A:59:04:35:23	STE2	192.168.200.7	STE2 - Eth	80	TCP setup=N, DHCP=N
00:0A:59:04:35:20	STE2	192.168.200.8	STE2 - Eth	80	TCP setup=N, DHCP=N



## First step

### Set device network parameters:

- IP address / HTTP port (80 by standard)
- Your network ask
- IP address of your network gateway
- Device name (optional parameter)

Save the settings by clicking on **Apply Changes**.

### Restore default settings:

- Right-click on the device MAC address. The default values from the HWg-Config can be restored by software mode during the first 60 settings after start-up.
- Press the RESET button, hold it down and connect the power source. Hold the button down for another 5 seconds until all the LEDs light up.

Details

Name: STE2 IP address: 192.168.100.62 [DHCP] Port: 80

Open in WEB Browser

Enable DHCP

Mask: 255.255.255.0 [DHCP] MAC: 00:0A:59:04:34:E7

Gateway: 192.168.100.1 [DHCP] FW version: 0.0.2

Enable IP access filter Device type: STE2 - Eth (78)

IP filter value: 0.0.0.0 DHCP: Supported

IP filter mask: 0.0.0.0

Enable NVT

Default values

Enable TCP setup Open

Enable TEA authorisation

Check if new IP address is empty

Cancel Apply changes

Ready

## 3 Device website

### Options of opening the website:

- Enter the device IP address in the browser window.
- Click on the IP address in the HWg-Config program.
- Click on the underlined IP address in the HWg-Config application.

HWg-Config 1.1.0 for HW group products (www.hw-group.com)

Version: 1.1.0 HW group, s.r.o. www.hw-group.com

Config utility for the HW group devices

Your PC network settings

IP address: 192.168.100.62

Netmask: 255.255.255.0

Gateway: 192.168.100.1

Find Devices

MAC	Name	* IP	Device type	Port	Parameters
00:0A:59:00:02:95	Dianosoles MINI	192.168.100.47	Dianosoles model MINI	80	TCP setup-Y, DHCP-P
00:0A:59:04:07:9E	SH4 server rack	192.168.100.49	SH4serverack	80	TCP setup-N, DHCP-P
00:0A:59:02:26:02	HWg SH4e	192.168.100.67	HWg SH4e	80	TCP setup-N, DHCP-P
00:0A:59:02:26:7F	HWg SH4e	192.168.100.69	HWg SH4e	80	TCP setup-N, DHCP-P
00:0A:59:02:26:82	HWg SH4e	192.168.100.69	HWg SH4e	80	TCP setup-N, DHCP-P
00:0A:59:04:09:59	HWg SH4 test2	192.168.100.69	HWg SH4test2	80	TCP setup-N, DHCP-P
00:0A:59:04:24:67	STE2	192.168.100.62	STE2 - Eth	80	TCP setup-N, DHCP-P
00:0A:59:04:02:90	HWg SH4 Hiawes	192.168.100.63	H		Show detail settings of device... HCP-P
00:0A:59:04:2E:59	PowsonQ 4002 Vbel	192.168.100.01	P		HCP-P
00:0A:59:04:05:3C	PowsonQ 4002 Den	192.168.100.01	P		Open in WEB Browser (port 80) HCP-P
00:0A:59:04:0F:30		192.168.100.141	I		Open TCP Setup (port 99) EA-N
00:0A:59:04:0F:4B		192.168.100.142	I		Download device configuration... EA-N
00:0A:59:04:23:30	STE2	192.168.200.2	S		Upload device configuration... HCP-P
00:0A:59:04:25:2C	STE2	192.168.200.5	S		HCP-P
00:0A:59:04:25:30	STE2	192.168.200.6	S		Load default values HCP-P
00:0A:59:04:25:23	STE2	192.168.200.7	S		Export Devices... HCP-P

Searching modules... 277 device(s) found on network, 277 device(s) filtered out Filter: All

## Home tab

Basic Info			
Device Name	Vitek Stul		
Time	16:17:17		
Date	08.01.2020		

Sensors & Digital Inputs			
state	name	type	current value
Normal	Sensor 2553	Humidity	41.8 %RH
Normal	Sensor 3553	Temp.	27.0 °C
Invalid	Sensor 6291	Temp.	-999.9 °C
Invalid	Sensor 6292	Humidity	-999.9 %RH
Normal	Input 1	Input Dry Contact	0 (Open)
Alarm	Input 2	Input Dry Contact	1 (Closed)

### — Base Information section

- **Device Name** – The device name serves to distinguish specific devices in larger installations. Can be set in the General Setup tab.
- **Time** – Current device time. The time can be set automatically from the internet or manually in the Time tab. In the case of automatic setting, the correct value is the indicator of device access to the internet.
- **Date** – Current device date. The date can be set automatically from the internet or manually in the Time tab. In the case of automatic setting, the correct value is the indicator of device access to the internet.

### — Sensors & Digital Inputs section

Lists the current values of sensors and digital DI inputs (Dry contacts)

- **State** – Input or sensor state.
  - **Normal** – Idle state, all normal.
  - **Alarm High** – Value exceeded the permitted upper limit.
  - **Alarm Low** – Value dropped below lower bottom limit.
  - **Alarm** – Digital input in the Alarm state (according to the Alarm Alert setting at the Digital Inputs tab).
- **Name** – Sensor name for better identification in larger systems. The name can be set in the Sensors or Digital Input tab.
- **Type** – Sensor type; indicates what type of sensor is in question (temperature / humidity / digital input).
- **Current Value** – Current value including unit of measure.

# General Setup tab



1.3.0

HOME GENERAL SETUP SECURITY WIFI SENSORS DIGITAL INPUTS EMAIL SMS ALARMS SNMP TIME PORTAL SYSTEM

General		
name	value	description
Device Name	<input type="text" value="Vitek Stul"/>	0 to 32 characters
WWW Info Text:	<input a&gt;"="" http:="" type="text" value="STE2 Rev2: For more information try &lt;a href='\" www.hw-group.com\"&gt;www.hw-group.com&lt;=""/>	
Temperature unit	<input type="text" value="Celsius"/>	Celsius/Fahrenheit/Kelvin
WWW Update period:	<input type="text" value="1"/>	[s] Automatic update period in seconds. 0=> disabled
Periodic restart	<input type="text" value="Off"/>	Periodic restart time

Network		
name	value	description
DHCP	<input checked="" type="checkbox"/>	DHCP Enable/Disable
IP Address	<input type="text" value="192.168.101.31"/>	A.B.C.D
Network Mask	<input type="text" value="255.255.252.0"/>	A.B.C.D
Gateway	<input type="text" value="192.168.100.1"/>	A.B.C.D
DNS Primary	<input type="text" value="192.168.100.237"/>	A.B.C.D
DNS Secondary	<input type="text" value="192.168.100.28"/>	A.B.C.D
HTTP Port	<input type="text" value="80"/>	Default 80
HTTPS Port	<input type="text" value="443"/>	Default 443. See https settings at <a href="#">Security page</a>

Device Admin		
name	value	description
Username	<input type="text"/>	Admin username/password for device configuration changes (0 to 16 characters)
Password	<input type="text"/>	

## — General section

- **Device Name** – Device name (STE2), allow you to distinguish individual the device in the network.
- **WWW Info Text** – Text at the foot of the website.
- **Temperature Unit** – Unit for displaying temperature. You can choose between Celsius / Fahrenheit / Kelvin. The Safe Range values will automatically be converted based on this option.
- **Periodic Restart** – Function to improve device stability in exposed networks allowing regular automatic restart of the device.

## — Network section

Only the cable connection parameters (RJ-45) are set here. Wireless connection parameters are set in the WiFi tab.

- **DHCP** – Permits the function of IP address setting by the DHCP server, if available. Enabling or disabling DHCP depends on the needs of the user and network administrator.
- **IP Address** – IP address of the device, allocated by the network administrator.
- **Network Mask** – Network mask, allocated by the network administrator.
- **Gateway** – IP address of the default gateway, allocated by the network administrator.
- **DNS Primary / DNS Secondary** – IP address of the DNS server, allocated by the network administrator.

- **HTTP Port** – Port number on which the built-in WWW server tunes in. A change of the port number is suitable e.g. for multiple devices accessible from the external network via a router. Consult the network administrator about potential changes. The default port is 80. You can turn off HTTP support by setting the port value to 0.
- **HTTPS Port** – The port number on which the embedded Web server listens for the secure HTTPS connection. Changing the port number is appropriate, for example, for multiple devices accesses from the external network via the router. Contact your network administrator for any change. The default port is 443. You can turn off HTTPS support by setting the port value to 0.

## — Device Admin section

- **Username / Password** – Username and password to secure access to the device.

## Security tab

## — HTTPS Server Certificate files

Used to manage certificates needed for the HTTPS server. Allows you to upload or delete a public key, a private key, or a certificate of the certificate authority (CA) that has issued the public key certificate.

## — Generate the SSL key and certificate

Generate a private SSL key and self-signed certificate for closed networks or testing purposes. The generated certificate is self-signed and will be displayed as untrusted. Please add the certificate

to the list of exceptions or use a certificate signed by a trusted certification authority. Please note that the generated data will replace the SSLCertificateFile and the SSLCertificateKeyFile. Generating the key can take up to 10 minutes. Do not restart the device and do not search for sensors. Otherwise the key generation will be interrupted.

## WiFi tab

When WiFi is off, only the enable option is shown:

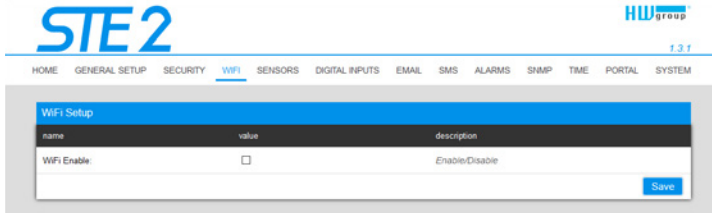

All the options are available after enabling:

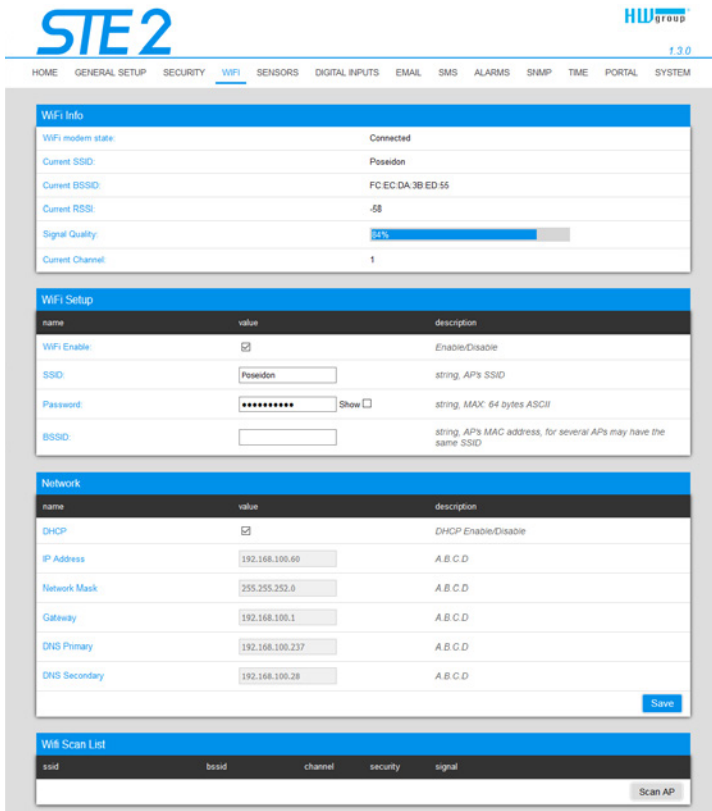

## — **WiFi modem state**

- **Disable** – WiFi is disabled.
- **Wait for power on** – Waits for WiFi module when power on.
- **Init** – Initializing of WiFi module.
- **Connecting** – Connecting.
- **SSID check** – SSID check.
- **Connected** – Connected to selected WiFi network.
- **Network WiFi scan** – Scan of available WiFi networks.
- **Wait for scan** – Waits for Network wifi scan.

## — **Information section**

- **Current SSID** – Current name of the network to which the device is connected. If the parameter is missing, the device is not connected to any WiFi network.
- **Current BSSID** – Current identifier of the WiFi network connection point. If the parameter is missing, the device is not connected to any WiFi network.
- **Current RSSI** – Relative strength of signal input. The higher the RSSI, the stronger the signal.
- **Signal Quality** – Strength of WiFi signal in % with graphic indicator.
- **Current Channel** – WiFi channel on which the device communicates. If the parameter is missing, the device is not connected to any WiFi network.

## — **WiFi Setup section**

- **WiFi Enable** – Enable or disable WiFi. By standard, the wireless interface is disabled. Device restart follows enabling.
- **SSID** – Name of the WiFi network to which should be the device connected. If you do not know your network name, use the Scan AP function at the bottom of the page.
- **Password** – Secured network password. If you do not know it, contact your network administrator.
- **BSSID** – Identifier of the WiFi network connection point (MAC address of the connection point).  
Optional data.

## — **Network section**

WiFi network parameters. [Only the wireless interface is set here. Cable Ethernet \(RJ-45\) is set in the General Setup tab.](#)

- **DHCP** – Permits the function of IP address setting by the DHCP server, if available. Enabling or disabling DHCP depends on the needs of the user and network administrator.
- **IP Address** – IP address of the device, allocated by the network administrator.
- **Network Mask** – Network mask, allocated by the network administrator.
- **Gateway** – IP address of default gateway, allocated by the network administrator.
- **DNS Primary / DNS Secondary** – IP address of the DNS server, allocated by the network administrator.

### **WiFi Scan List**

- **SSID** – Name of found WiFi network.
- **BSSID** – Connection point identifier (MAC address).
- **Channel** – WiFi channel on which the connection point operates.
- **Security** – Type of secured WiFi communication.
- **Signal** – Signal level in DB. The higher the value, the better. WARNING, -60 is more than -90! The highlighted row indicates the currently connected AP.

### Connecting to found WiFi

- Click on the SSID of the found network to prefill WiFi setting and just enter the Password. The BSSID remains empty. Standard setting. Reconnects automatically if AP is changed.
- Clicking on BSSID will prefill not only the network name (SSID), but also the MAC address of the specific AP (BSSID). The device then connects to this AP and will not try to reconnect in the case of aggregated networks.

### Scan AP

The screenshot shows a network configuration interface. At the top, there are two rows for DNS settings:

- DNS Primary: 192.168.1.1 (with a dropdown menu showing A B C D)
- DNS Secondary: 0.0.0.0 (with a dropdown menu showing A B C D)

A "Save" button is located to the right of the DNS settings.

Below the DNS settings is a section titled "WiFi Scan List" with a blue header. It contains a table with the following columns: ssid, bssid, channel, security, and signal. The signal column uses a blue progress bar to indicate the signal strength percentage.

ssid	bssid	channel	security	signal
Posedon	82:2A:A8:2D:2A:9B	6	WPA2 PSK	55%
	82:2A:A8:2D:2A:9B	6	WPA2 PSK	55%
	FE:EC:DA:3E:38:32	11	WPA2 PSK	56%
Posedon	FE:EC:DA:3E:38:32	11	WPA2 PSK	52%
	06:18:D6:A9:28:EE	6	WPA2 PSK	44%
Testoma	00:04:56:A0:34:D0	11	WPA2 PSK	40%
Posedon	04:18:D6:A9:28:EE	6	WPA2 PSK	36%
	FE:EC:DA:3B:ED:55	1	WPA2 PSK	26%
Posedon	FE:EC:DA:3B:ED:55	1	WPA2 PSK	22%
Posedon	FE:EC:DA:3E:39:E6	1	WPA2 PSK	20%
	FE:EC:DA:3E:39:E6	1	WPA2 PSK	20%
ASUS	50:46:5D:8D:1A:78	12	WPA WPA2 PSK	16%

A "Scan AP" button is located at the bottom right of the WiFi Scan List section.

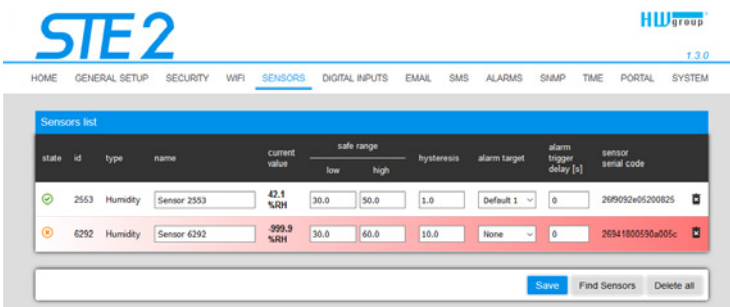

## — Sensor List section \*

- **State** – Input or sensor state.
  - 🟢 **Normal** – Idle state, all normal.
  - 🔴 **Alarm High** – Value has exceeded permitted upper limit.
  - 🔴 **Alarm Low** – Value has dropped below permitted lower limit.
- **ID** – Sensor ID identical to ID in Poseidon2 and STE2 units.
- **Type** – Sensor type; determine what type of sensor is in question (temperature / humidity / DI input).
- **Name** – Sensor name for better identification in larger systems. The name can be set in the Sensors or Digital Input tab.
- **Current Value** – Current value including unit of measure.
- **Safe Range** – Range of permitted values. If the current value exceeds the Safe Range, an Alarm is activated.
- **Hysteresis** – Defines the insensitivity zone if the limit values are exceeded; prevents the activation of multiple alarms if the temperature oscillates around the limit value.
- **Alarm Target** – Specifies the targets for alarm alerts (SMS + E-mail). Target recipients are defined at the Alarms tab. The drop-down menu allows selecting an existing set of targets or creating a new one.
- **Alarm Trigger Delay [s]** – Delays the alarm start alert by a specified time.
- **Code** – Full ID of the 1-Wire sensor.
- 🗑️ **Delete** – Button to delete the specific sensor.

\* Sensors in Alarm state are highlighted.



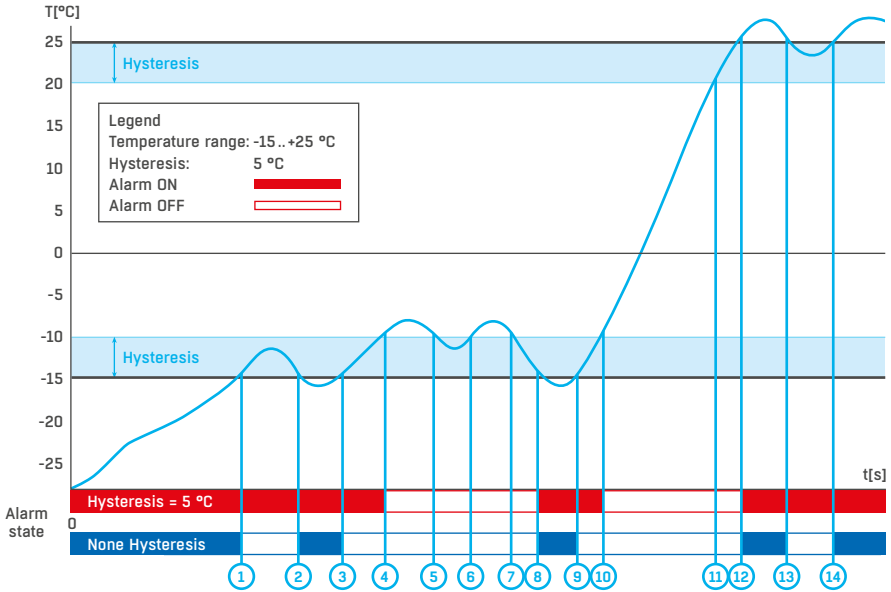

## Digital Inputs tab

STE2 HWgroup 1.3.0

HOME GENERAL SETUP SECURITY WIFI SENSORS DIGITAL INPUTS EMAIL SMS ALARMS SNMP TIME PORTAL SYSTEM

id	current state	name	state name		alarm alert	alarm target	alarm trigger delay [s]
			log 0	log 1			
1	0 (Open)	Input 1	Open	Closed	1 (Active if Close)	None	0
2	1 (Closed)	Input 2	Open	Closed	1 (Active if Close)	None	0

Save

### — Sensor List section\*

- **ID** – Indication of the input variable within the device.
- **Current State** – List of current input state ("0 (Off)" / "1 (On)").
- **Name** – Input name in 12 characters (e.g. "2F left door", "smoke section 1").
- **Alarm Alert** – Definition of Alarm state for each input.
- **Alarm Target** – Specifies the targets for alarm alerts (SMS + E-mail). Target recipients are defined at the Alarms tab. The drop-down menu allows selecting an existing set of targets or creating a new one.
  - **Active if Close** – Alarm active if the input is in state 1 (On).
  - **Active if Open** – Alarm active in input is in state 0 (Off).
  - **Disabled** – Input does not have a defined Alarm state.
- **Alarm Trigger Delay [s]** – Delays the alarm start alert by a specified time.

\* DI inputs in Alarm state are highlighted.

Email Settings		
name	value	description
SMTP Server	<input type="text" value="mail.hw.cz"/>	IP Address or DNS Name
SMTP Port	<input type="text" value="587"/>	Default 25
Authentication	<input type="checkbox"/>	Enable/Disable
Secure TLS mode	<input type="checkbox"/>	Enable/Disable
Use HTML formatting	<input checked="" type="checkbox"/>	Uses html to format email message body.
Username	<input type="text" value="smtp"/>	0 to 32 characters
Password	<input type="password" value="*****"/>	0 to 32 characters
Importance	<input type="text" value="Normal"/>	Email importance flag
FROM	<input type="text" value="ste2@hwg.cz"/>	Device email address
Subject	<input type="text" value="STE2 na stole"/>	Beginning of email subject

[Save](#)

Email Test Log		
Email address	<input type="text" value="recipient@domain.com"/>	Email for testing
<input type="text"/>		Debug log window

[Test Email](#)

### — E-mail Settings

- **SMTP Server** – IP address or domain address of the SMTP server.
- **SMTP Port** – Port number on which the e-mail server tunes in – 25 by standard.
- **Authentication** – Enable authentication; check if the SMTP server requires authentication.
- **Secure TLS mode** – Check if the SMTP server requires secure communication via SSL/TLS.
- **Username** – Username for SMTP server authentication. If the Authentication field is not checked, the content of this field is irrelevant.
- **Password** – Password for SMTP server authentication. If the Authentication field is not checked, the content of this field is irrelevant.
- **Importance** – Sets priority of the e-mail message. Important for filtering and further processing of alarm messages.
- **FROM** – Sender's e-mail address, i.e. of the device. The address may be required by the SMTP servers and can be used to identify the device or to filter and further process alarm messages.
- **Subject of e-mail** – The field content can be used to identify the device, or for filtering and further processing of alarm messages.

### — Email Test Log section

In this section, the SMTP server settings can be tested. Click Test Email to send a test e-mail to the specified Email address. The Debug log window shows the communication with the SMTP server.

## SMS tab

With the Wifi turned off, only the power-on option is shown:

The screenshot shows the STE2 web interface with the 'SMS' tab selected. The top navigation bar includes 'HOME', 'GENERAL SETUP', 'SECURITY', 'WIFI', 'SENSORS', 'DIGITAL INPUTS', 'EMAIL', 'SMS', 'ALARMS', 'SNMP', 'TIME', 'PORTAL', and 'SYSTEM'. The 'SMS' section is titled 'Remote SMS gateway' and contains a table with the following fields:

name	value	description
Enable	<input checked="" type="checkbox"/>	Enable/Disable
SMS Gateway Address	<input type="text" value="remote.hwgroup.cz"/>	IP Address or DNS Name
Port	<input type="text" value="8085"/>	Default 80
Username	<input type="text" value="hwgroup"/>	
Password	<input type="password" value="*****"/>	

Below the configuration table is a 'Save' button. The 'SMS Test Log' section contains a 'Phone number' field with the value '77732739' and a 'Debug log window' area. At the bottom right of the 'SMS Test Log' section are 'Test SMS' and 'Test Call' buttons.

### — Remote SMS gateway

- **Enable** – Turns on the SMS sending function. For sending, the SMS alarm action must be set at the sensor or input.
- **SMS Gateway Address** – IP address where “HWg-SMS-GW3” is located through which the device will send SMS. It can be set including service - typically /service.xml
- **Port** – The TCP port on which the gateway listens.
- **Username** – User name for authorization in SMS GW.
- **Password** – Password for authorization in SMS GW.
- **SMS + Ring When Alarm** – Enables sending a SMS and then dialing the number.

### — SMS Test Log

In this section, the SMS gateway settings can be tested.

- **Test SMS** – Sends a test text message to the specified Phone number.
- **Test Call** – Dials the specified Phone number.
- **Debug log window** – Shows the communication with the SMS gateway.

## Alarms tab

Alarm targets are defined at this tab. Up to 2 sets of targets can be created; each set can contain up to 2 addresses for e-mail alerts and 2 phone numbers for text message alerts and calls. These sets are then assigned to individual sensors and digital inputs. To create a set, click the + button at the Alarms tab, or select Add new... when editing a sensor or a digital input.

The screenshot shows the STE2 web interface with the 'ALARMS' tab selected. The page title is 'STE2' and the version is '1.3.0'. The navigation menu includes: HOME, GENERAL SETUP, SECURITY, WIFI, SENSORS, DIGITAL INPUTS, EMAIL, SMS, ALARMS, SNMP, TIME, PORTAL, SYSTEM. The 'Alarms' configuration window is titled 'Default 1' and contains the following fields:

- Alarm Target:** Default 1
- email address:** A header for the email section.
- Email list:** Two input fields, both containing 'example@hvg.cz'.
- phone number:** A header for the phone number section.
- SMS list:** Two input fields, both containing '+420603603603', each with a checkbox to its right.
- call:** A header for the call section.
- Save:** A button at the bottom right of the configuration window.

### — Alarm Target

Set of targets. For clarity, the set can be given a custom name.

- **Email list** – E-mail addresses of alarm alert recipients. To send e-mails, the SMTP server must be properly configured at the Email tab.
  - **Email address** – Each field may contain only one e-mail address.
- **SMS list** – Phone numbers for text message alarm alerts. To send a message, the SMS gateway must be properly configured at the SMS tab.
  - **Phone number** – Each field may contain only one phone number.
  - **Call** – When checked, the phone number is dialed after the text message is sent (an incoming text alone can be easy to overlook).

# SNMP tab

The SNMP tab sets the parameters for communication via SNMP protocol.

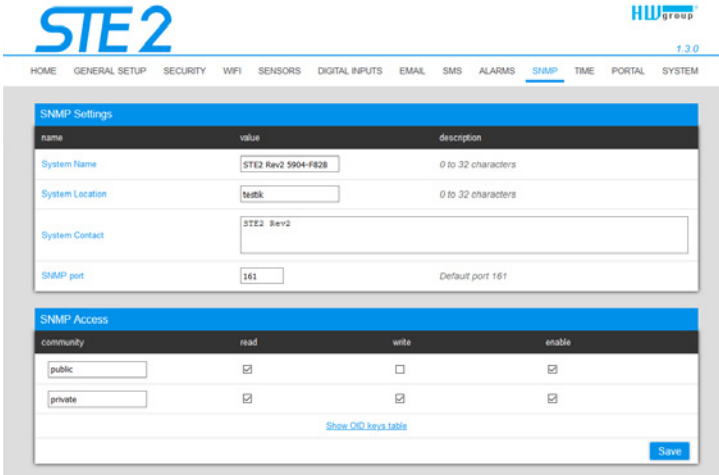

## — General SNMP Settings section

- **System Name** – Device name within SNMP.
- **System Location** – Device location within SNMP.
- **System Contact** – Contact of the device administrator within SNMP.
- **SNMP port** – Port number on which communication via SNMP is possible – 161 by standard.

## — SNMP Access section

- **Community** – Name of SNMP community for access to the device via SNMP. 2 communities can be defined. For each Community you can define whether it has rights for:
  - **Read**
  - **Write**

## — Show OID keys table

This function writes up the entire tree of variables with indication of the entire SNMP OID and explanations of the type of variable. For connecting the device to third-party monitoring systems, there is also an MIC file under the Download MIB file link.

# STE2

HWgroup

1.3.0

HOME GENERAL SETUP SECURITY WIFI SENSORS DIGITAL INPUTS EMAIL SMS ALARMS SNMP TIME PORTAL SYSTEM

oid key	value	description	data type	access
1.3.6.1.2.1.1.1.0	STE2 Rev2 5904-F88E	System Description	string	RO
1.3.6.1.2.1.1.2.0	1.3.6.1.4.1.21796.4.9.	System ObjectID	objid	RO
1.3.6.1.2.1.1.3.0	7860100	System UpTime	timebcks	RO
1.3.6.1.2.1.1.4.0	STE2 Rev2	System Contact	string	RO
1.3.6.1.2.1.1.5.0	STE2 Rev2 5904-F88E	System Name	string	RO
1.3.6.1.2.1.1.6.0		System Location	string	RO
1.3.6.1.2.1.1.7.0	72	System Services	integer	RO
1.3.6.1.4.1.21796.4.9.1.1.1.1	1	1 Input Index	integer	RO
1.3.6.1.4.1.21796.4.9.1.1.1.2	2	2 Input Index	integer	RO
1.3.6.1.4.1.21796.4.9.1.1.2.1	0	1 Input Value, 0=Open, 1=Close	integer	RO
1.3.6.1.4.1.21796.4.9.1.1.2.2	0	2 Input Value, 0=Open, 1=Close	integer	RO
1.3.6.1.4.1.21796.4.9.1.1.3.1	Input 1	1 Input Name	string	RO
1.3.6.1.4.1.21796.4.9.1.1.3.2	Input 2	2 Input Name	string	RO
1.3.6.1.4.1.21796.4.9.1.1.4.1	0	1 Input State, 0=Normal, 1=Alarm	integer	RO
1.3.6.1.4.1.21796.4.9.1.1.4.2	0	2 Input State, 0=Normal, 1=Alarm	integer	RO
1.3.6.1.4.1.21796.4.9.70.1.0	00:0A:59:04:F8:8E	System MAC address	string	RO

# Time tab

The system time and parameters of optional automatic synchronisation via time servers is sent in the Time tab.



## — SNTP Settings

- **SNTP Server** – IP address or domain address of the time synchronisation server; default time. nist.gov.
- **Time Zone** – Setting of the time zone based on the device location. Serves to set the correct system time. Required for correct recording of measured values.
- **Summertime** – Enable summer time. Serves to set the correct system time. Required for correct recording of measured values.
- **Interval** – Interval of time synchronisation with the server.

## — Time Settings

The Time Setup section enables filling in the current date and time manually, if synchronisation with the time server cannot be used.

## — SNTP Log

The Sync button serves to perform instant synchronisation with the time server. It can also be used to test settings.

## Portal tab

The tab serves to set parameters for sending data to a remote portal via HWg-PUSH protocol. More about the protocol or support of portal solutions is available on the website <http://www.HW-group.com>.

The screenshot shows the STE2 web interface with the 'Portal' tab selected. The interface includes a navigation menu at the top with options like HOME, GENERAL SETUP, SECURITY, WIFI, SENSORS, DIGITAL INPUTS, EMAIL, SMS, ALARMS, SNMP, TIME, PORTAL, and SYSTEM. The 'Portal' section is divided into three main areas:

- Portal Message:** A text box containing the message: "Portal: Check sensor online (2020-01-09 15:36:44 UTC)".
- Portal settings:** A table with columns 'name', 'value', and 'description'. It contains settings for 'Portal' (checked), 'Server Address' (http://remote.hwgroup.cz/portal.php), 'IP Port' (3080), 'Team' (vtolnr), and 'Team Password' (masked with asterisks). A 'Save' button is located at the bottom right of this section.
- Portal Debug Log:** A table with columns 'name', 'value', and 'description'. It lists various timers and counts such as 'Push Period' (900), 'Log Period' (300), 'Current Push Timer' (170), 'Current Log Timer' (67), 'Current Check Timer' (0), 'AutoPush Block Timer' (0), and 'Retransmit number' (0). A 'Manual Push' button is located at the bottom right of this section.

### — Portal Message section

Feedback from the portal containing e.g. links to graphs, etc. Depends on the portal type.

### — Portal settings section

- **Portal** – Enables or disables this function.
- **Server address** – Complete URL of the remote server. Connection to the [www.SensDesk.com](http://www.SensDesk.com) is pre-set in the device.
- **IP Port** – Port which the portal tunes in to.
- **Team** – Name of the Team to which the device should be assigned.
- **Team Password** – Password of the Team to which the device should be assigned.



### — *Input(s) AutoPush config section*

Sets the behaviour of AutoPush for DI inputs. During activation, the sending of information about changes in the input state to the portal is accelerated. The function can be enabled individually for each input.

### — *Sensor(s) AutoPush config*

Sets the behaviour of the AutoPush function for individual sensors. The function accelerates the sending of information about fluctuating values to the portal. When the measured sensor value changes since last communication with the portal by more than the defined value, the device connects to the portal again and sends the new value.

### — *Portal Debug Log section*

For debugging only. Event counters + Debug window for sending data to the portal.

- *Push Period* – Period of sending data to the remote portal. The period is determined by the portal and cannot be changed by the user.
- *Log Period* – Period of storing data for the portal in the cache. The period is determined by the portal and cannot be changed by the user.
- *Current Push Timer* – Timer indicating the time remaining until sending data to the portal.
- *Current Log Timer* – Timer indicating the time remaining until saving the data for the portal in the cache.
- *AutoPush Block Timer* – Time of incidents for AutoPush. If the permitted number of incidents for one Push period is exceeded, the AutoPush function will be blocked.
- *Retransmit number* – Counts the number of invalid Push attempts.
- *Manual Push* – Button for instant sending of data to the portal.

### — *What is AutoPush*

- *AutoPush* – By default, the device thermometer sends data to the portal at a fixed interval defined by the relevant portal (in the case of the SensDesk portal, once every 15 minutes) and the user cannot change this value. A special case is the start and end of Alarms, when extraordinary sending will occur. AutoPush serves for the extraordinary sending of values also whenever the sensor value changes by more than the defined AutoPush value.

This concerns only the setting of communication between the device and the online portal. The values of local alarms are set in the portal.

# System tab

The screenshot shows the STE2 web interface. At the top, there is a navigation menu with items: HOME, GENERAL SETUP, SECURITY, WIFI, SENSORS, DIGITAL INPUTS, EMAIL, SMS, ALARMS, SNMP, TIME, PORTAL, and SYSTEM (which is highlighted). The main content area is divided into two sections: 'Download' and 'System'.

**Download**

description	file
Backup configuration	<a href="#">STE2_Rev2_Config.bin</a>
Online setup in XML	<a href="#">setup.xml</a>
Online values in XML	<a href="#">values.xml</a>
SNMP MIB Table	<a href="#">STE2_Rev2.mib</a>
OID keys table	<a href="#">Online.OID.keys.table</a>
TXT list of common SNMP OIDs	<a href="#">STE2_Rev2_OID.txt</a>

**System**

name	value
Product Name	STE2 Rev2
Serial Number	6006990035
Eth MAC Address	00:0A:59:04:F8:2D
Wi6 STA MAC Address	00:0A:59:04:F8:2D
Version	1.3.0
Build	349
Compile time	Nov 27 2019, 21:28:46
Up Time	22473 [s]
Demo Mode	<a href="#">Demo Mode</a>
Network Upgrade	<a href="#">Read available version --</a> <a href="#">Start Network Upgrade --</a>
Upload Firmware or Configuration	<input type="button" value="Browse..."/> No file selected. <input type="button" value="Upload"/>

At the bottom right of the interface, there are two buttons: 'Restart' and 'Factory reset'.

## — Download section

- **Backup configuration** – Configuration backup in BIN format. Click on the link to save the current device configuration after its final settings for potential restore purposes.
- **Online setup in XML** – Configuration backup in XML format. Click on the link to save the current device configuration after its final settings for potential restore purposes.
- **Online values in XML** – Current values in XML format. Click on the link to save the current device configuration after its final settings for potential restore purposes.
- **SNMP MIB Table** – SNMP MIB file. MIB file address containing the definition of SNMP variables.
- **OID keys table** – The function will draw up the entire tree of variables with indication of the entire SNMP OID and explanations of the variable type.
- **TXT list of common SNMP OIDs** – Overview of most important OID from the MIB table.

## — System section

- **Product Name** – Device name (type).
- **Serial Number** – Device serial number.
- **Eth MAC Address** – MAC address of device for cable connection.
- **WiFi STA MAC Address** – MAC address of device for WiFi connection.
- **Version** – Firmware version. Serves for diagnostic purposes when solving problems.
- **Build** – Serves for diagnostic purposes when solving problems.
- **Compile time** – Firmware compile time. Serves for diagnostic purposes when solving problems.
- **UpTime** – Runtime of the device since last switching on or restart. Serves for diagnostic purposes when solving problems.
- **Demo mode** – Active demo mode prevents any changes in your device configuration. In this mode, users can browse and view all the web interface pages, but they are not allowed to change any values. A device with this setting can be placed on the public internet with no risk of changes in its configuration.
- **Read available version** – Lists the latest version of firmware on the HW group update server.
- **Start Network Upgrade** – Launches a firmware upgrade from the HW group update server.
- **Upload Firmware or Configuration** – Install newer firmware or configuration files to the device. Restore configuration may not work if there is too large a difference in firmware versions.

## — Factory Default section

Restores factory settings. The default IP address is 192.168.10.20 and the username and password are not defined.

## — System Restart section

Restarts the device.

## Technical parameters

Ethernet	
Interface	RJ45 (10/100BASE-T)
Supported protocols	IP: ARP, TCP/IP (HTTP, HTTPS, SNMP, SMTP, HWg-Push, netGSM, TLS), UDP/IP (SNMP)
SNMP	Version 1 fully supported, some parts version 2

WiFi	
Supported standards	802.11 b/g/n
Frequency	2,4GHz
Output	+19.5 dBm output power in 802.11b mode +16 dBm for 802.11n
Security	WEP / WPA / WPA2 PSK / WPA2 TSK / WPS
Antenna	Internal

External sensors	
Port / connector	Port1, Port2 / RJ11 (1-Wire)
Connectability	Three external temperature or humidity sensors. One combined temperature + humidity sensor can be connected.
Sensor type	Only sensors from HW group s.r.o.
Sensors / distance	Max 3 sensors / Max 60 metres total length

DI INPUTS (Dry Contact Inputs)	
Port / connector	I1, I2 / Ø 2 mm bracket
Type	Digital Input (supports NO/NC Dry contact)
Sensitivity	1 (On) = 0-500 Ohm (Right pin on the terminal block can be connected to 12V GND)
Max. distance	Up to 50m

Power supply	
Power voltage	5V / 250 mA
Connector	Jack Ø3.5 x 1.35 / 10 [mm]
PoE (Power over Ethernet)	RJ45 - IEEE 802.3af Class 0

LED	
LINK	Green – Ethernet connection state
Activity	Yellow – Ethernet activity
Alarm	Port 1 – Alarm SENS – Shines if alarm active on sensor Port 2 – Alarm DI – Shines if alarm active on sensor
IN	Yellow – activation of the contact
WiFi	Blue – connection state in operation (shining), search indicator (flashing slowly) and connection (flashing quickly)

Button	
Reset	Restore default settings: hold or 5 seconds after connecting power supply.

Other parameters	
Operating temperature	-10 to 60 °C (range of device operating temperatures – may not correspond to sensor range)
Dimensions/weight	65 x 80 x 30 [mm] / 500 g
Elmag. radiation	CE / FCC Part 15, Class B
Elmag. compatibility	EN 55022, EN 55024, EN 61000

# Physical dimensions

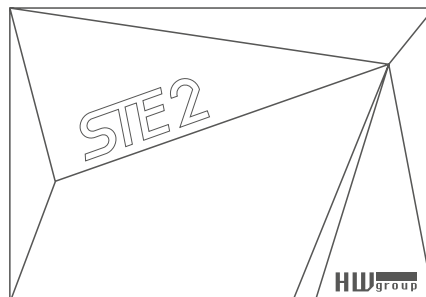
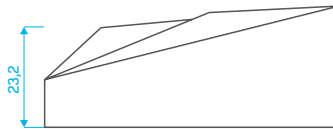
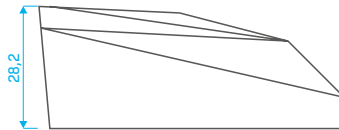
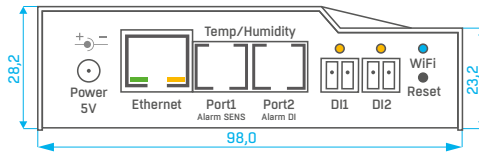
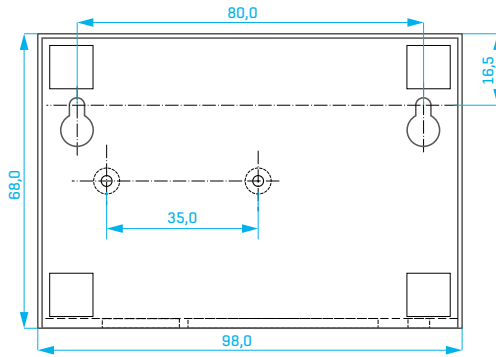

# WiFi Radio

Description	Min	Typical	Max	Unit
Input frequency	2412	-	2484	MHz
<b>Tx power</b>				
Output power of PA for 72.2 Mbps	13	14	15	dBm
Output power of PA for 11b mode	19,5	20	20,5	dBm
<b>Sensitivity</b>				
DSSS, 1 Mbps	-	-98	-	dBm
CCK, 11 Mbps	-	-91	-	dBm
OFDM, 6 Mbps	-	-93	-	dBm
OFDM, 54 Mbps	-	-75	-	dBm
HT20, MCS0	-	-93	-	dBm
HT20, MCS7	-	-73	-	dBm
HT40, MCS0	-	-90	-	dBm
HT40, MCS7	-	-70	-	dBm
MCS32	-	-89	-	dBm
<b>Adjacent Channel Rejection</b>				
OFDM, 6Mbps		37		dB
OFDM, 54Mbps		21		dB
HT20, MCS0		37		dB
HT20, MCS7		20		dB

## WiFi signal strength

### — What is signals strength

WiFi is a radio signal and it has limitations in reach given firstly by the transmission output and by the quality and shape of the antennas. Signal strength is indicated in decibels per miliwatt of output (dBm), often (incorrectly) simplified to “dB”. Signal strength has a negative value and it applies that the lower the value (a higher number after the negative sign), the worse.

The decibel unit is non-dimensional and expresses the logarithm of a ratio of two values. In our case, it is the ratio of received output to an etalon of 1 mW:

$$dBm = 10 * \log_{10} \frac{P_1}{1 \text{ mW}}$$

*This means that if you have a signal of -54 dBm, it is higher (better) than a value of -82 dBm.*

# Impact of device position vis-à-vis the transmitter (router or AP)

The device uses a flat antenna similar to mobile telephones or laptops, while the connection points generally use multi-directional antennas (rods). Flat antennas have the same or better sensitivity as multi-directional antennas (the transition connector is omitted), but its primary disadvantages include sensitivity to the positioning of the device vis-à-vis the connection point.

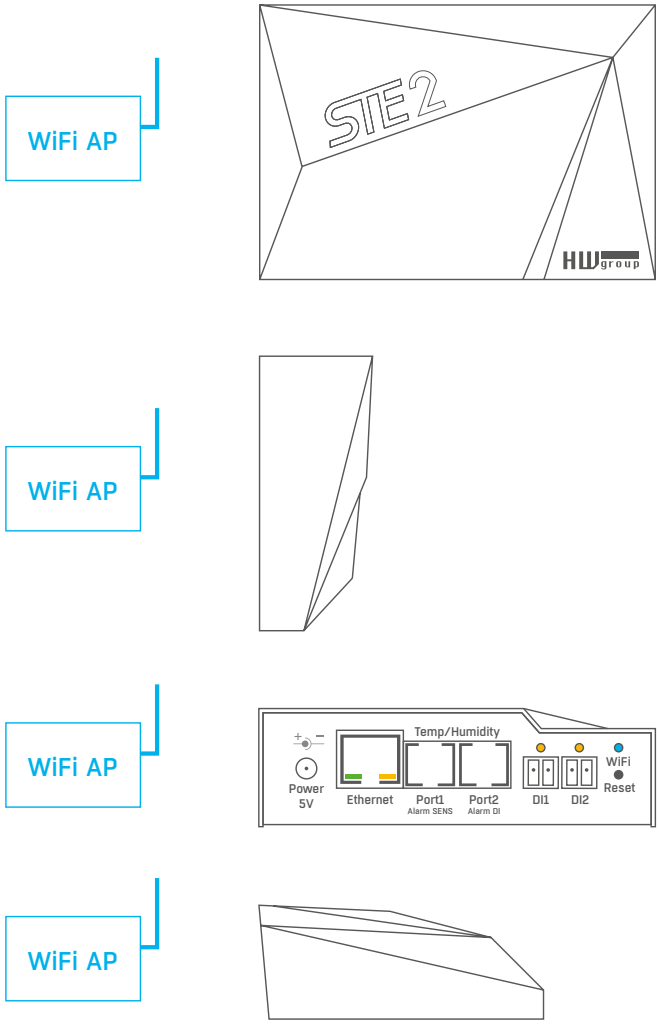

## Supported interfaces

### Dry contact Inputs

Dry contacts can be connected to the brackets.  
For instance door contacts.

The inputs are galvanically connected to the power supply.

- **Unconnected input** has a value of „**0 (Off)**“.
- **Active input** is identified as „**1 (On)**“, Ohmic resistance of the input against the Common bracket must range between 0  $\Omega$  and 500  $\Omega$ .



#### — Connection parameters:

- **Maximum cable length:** 50 metres.
- **Supported sensors:** Any dry contact.
- **Alarm setting for each DI input**
  - Alarm inactive.
  - Alarm state when the contact is activated or deactivated.
  - Alarm state when the contact is deactivated.
- **Options for reacting to Alarm state:** Common settings for all inputs.
  - No reaction.
  - Notify of Alarm by sending e-mail or SMS.
- **Reading period:** 800 ms.
- **Range of ID sensors:** Inputs use address ID in the range of 1 to 9.
- **Sensor name:** The sensor can be named independently with up to 12 characters.
- **Sensor disconnection detection:** No, the disconnected sensor returns to the value „**0 (Off)**“.

### RJ11 – 1-Wire bus

Digital bus by Dallas Semiconductor, each sensor has a unique ID.

We recommend lines up to a total length of 60 m. There are known cases of experimentation with bus function up to a distance of tens to hundreds of metres.

Flawless functioning cannot be guarantee for cables lines than 60 m from one connector on the device. It depends on the make of the cable, topology of the line and environment where the line is installed.





## Active / Passive 1-Wire port

- **Active port:** RJ11 connector on the device. It guarantees full maximum distance of the sensors and power supply for all sensors.

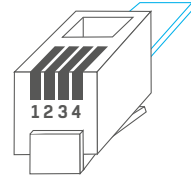

When you reconnected the connected sensor from one active port to another, the sensor shows up as disconnected. You must restart automatic sensor detection.

- **Passive port:** RJ11 connector on the T-Hub router or RJ11 connector from the sensor (if sensors are chained).

RJ11		
1	-	Not used
2	Data	Transmit Data
3	GND	Ground
4	+5V	Power

## Sensor Hysteresis

The Hysteresis value defines the width of the tolerance range for sending an alarm. The function prevents the occurrence of multiple alarms in cases when the value oscillates around the defined value. The function is apparent from the graph.

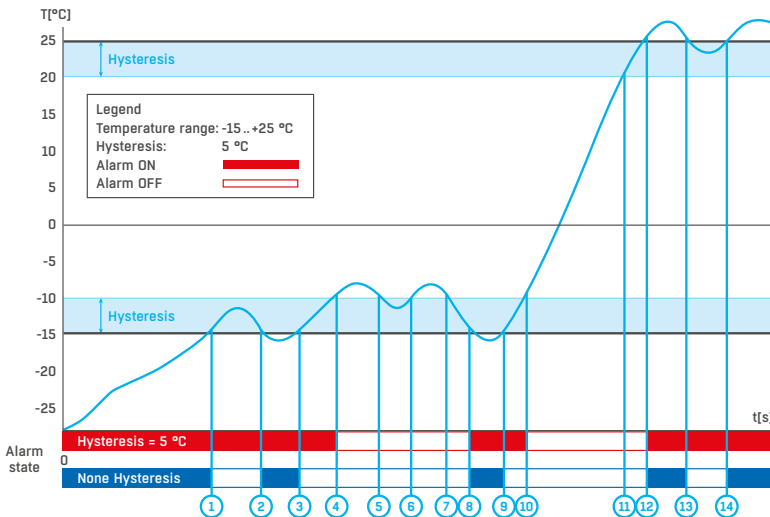

Within the internal 5°C hysteresis band, the alarm would be activated in **point 8** and would end in **point 9**. Because of the hysteresis function, the alarm is extended until the temperature reaches the end of the hysteresis zone (point 10) 5 °C + (-15 °C) = -10 °C.

- **Hysteresis (=5 °C):** The unit sends **3** e-mails (SMS) Alarm at points **0..4, 8..10, 12** and upwards.
- **Without hysteresis (0 °C):** The unit sends **8** e-mails (SMS) Alarm at points **0..1, 2..3, 8..9, 12..13, 14** and upwards.

# Connecting STE2 to the SensDesk portal

- 1 Connect the device to the computer network and set the network parameters (see the **First Steps** chapter).

HWg-Config 1.1.1 for HW group products (www.hw-group.com)

Version: 1.1.1  
HW group, s.r.o.  
www.hw-group.com  
Config utility for the HW group devices

Your PC network settings:  
IP address: 192.168.200.4  
Netmask: 255.255.252.0  
Gateway: 192.168.200.1

Device list:

MAC	Name	*IP	Device type	Port	Parameters
00:0a:59:04:33:0c	STE2	192.168.100.41	STE2-Eth	80	TCP setup=N, DHCP=Y
00:0a:59:04:34:83	STE2	192.168.100.51	STE2-Eth	80	TCP setup=N, DHCP=Y
00:0a:59:04:33:63	STE2	192.168.100.79	STE2-Eth	80	TCP setup=N, DHCP=Y
00:0a:59:04:34:15	STE2	192.168.100.123	STE2-Eth	80	TCP setup=N, DHCP=Y
00:0a:59:04:33:90	STE2	192.168.200.2	STE2-Eth	80	TCP setup=N, DHCP=Y
00:0a:59:04:35:2c	STE2	192.168.200.5	STE2-Eth	80	TCP setup=N, DHCP=Y
00:0a:59:04:35:20	STE2	192.168.200.6	STE2-Eth	80	TCP setup=N, DHCP=Y
00:0a:59:04:35:23	STE2	192.168.200.7	STE2-Eth	80	TCP setup=N, DHCP=Y
00:0a:59:04:35:29	STE2	192.168.200.8	STE2-Eth	80	TCP setup=N, DHCP=Y
00:0a:59:04:35:1a	STE2	192.168.200.9	STE2-Eth	80	TCP setup=N, DHCP=Y
00:0a:59:04:35:14	STE2	192.168.200.10	STE2-Eth	80	TCP setup=N, DHCP=Y
00:0a:59:04:35:06	STE2	192.168.200.11	STE2-Eth	80	TCP setup=N, DHCP=Y
00:0a:59:04:35:38	STE2	192.168.200.12	STE2-Eth	80	TCP setup=N, DHCP=Y
00:0a:59:04:35:7c	STE2	192.168.200.13	STE2-Eth	80	TCP setup=N, DHCP=Y
00:0a:59:04:33:0c	STE2	192.168.200.14	STE2-Eth	80	TCP setup=N, DHCP=Y
00:0a:59:04:32:f4	STE2	192.168.200.15	STE2-Eth	80	TCP setup=N, DHCP=Y
00:0a:59:04:33:09	STE2	192.168.200.16	STE2-Eth	80	TCP setup=N, DHCP=Y
00:0a:59:04:32:cc	STE2	192.168.200.17	STE2-Eth	80	TCP setup=N, DHCP=Y
00:0a:59:04:33:a6	STE2	192.168.200.18	STE2-Eth	80	TCP setup=N, DHCP=Y
00:0a:59:04:34:fd	STE2	192.168.200.20	STE2-Eth	80	TCP setup=N, DHCP=Y
00:0a:59:04:34:e4	STE2	192.168.200.21	STE2-Eth	80	TCP setup=N, DHCP=Y
00:0a:59:04:34:d8	STE2	192.168.200.22	STE2-Eth	80	TCP setup=N, DHCP=Y

Searching modules... 233 device(s) found on network, 130 device(s) filtered and displayed Filter: STE2 - Eth

- 2 Check the device website:

# STE2

HW group 1.3.0

HOME GENERAL SETUP SECURITY WIFI SENSORS DIGITAL INPUTS EMAIL SMS ALARMS SHMP TIME PORTAL SYSTEM

### Basic Info

Device Name	Weak Stul
Time	16:17:17
Date	08.01.2020

### Sensors & Digital inputs

state	name	type	current value
Normal	Sensor 2553	Humidity	41.8 %RH
Normal	Sensor 3553	Temp	27.6 °C
Invalid	Sensor 6291	Temp	999.9 °C
Invalid	Sensor 6292	Humidity	999.9 %RH
Normal	Input 1	Input Dry Contact	0 (Open)
Alarm	Input 2	Input Dry Contact	1 (Closed)

- 3 Tick the *Enable Portal* option and save the changes using the *Save* button in the bottom right corner of the window. Then click the *Manual Push* button in order to activate the portal function. Instead of “Portal disabled”, a link *SensDesk.com: register your IP sensor* should appear in the *Portal Message* field. Click this link in order to get to the [SensDesk.com](https://sensdesk.com) portal.

The screenshot shows the STE2 web interface with the 'PORTAL' tab selected. The 'Portal Message' field contains a link: [SensDesk.com: register your IP sensor and IP, Team and Team Password correctly. \(2020-02-09 14:12:31 UTC\)](https://sensdesk.com). The 'Portal settings' table is as follows:

name	value	description
Portal	<input checked="" type="checkbox"/>	Portal Enable/Disable
Server Address	<input type="text" value="http://sensdesk.com/portal.php"/>	IP Address or DNS Name
IP Port	<input type="text" value="80"/>	Default 80
Team	<input type="text"/>	Push device access parameters see at <a href="#">My account</a> on Sensdesk
Team Password	<input type="text"/>	

A 'Save' button is located at the bottom right of the settings section. Below it is the 'Portal Debug Log' table:

name	value	description
Push Period:	10	[seconds]
Log Period:	0	[seconds]
Current Push Timer:	13	[seconds]
Current Log Timer:	0	[seconds]
Current Check Timer:	0	[seconds]
AutoPush Block Timer:	0	[seconds]
Retransmit number:	1	

A 'Manual Push' button is located at the bottom right of the debug log section.

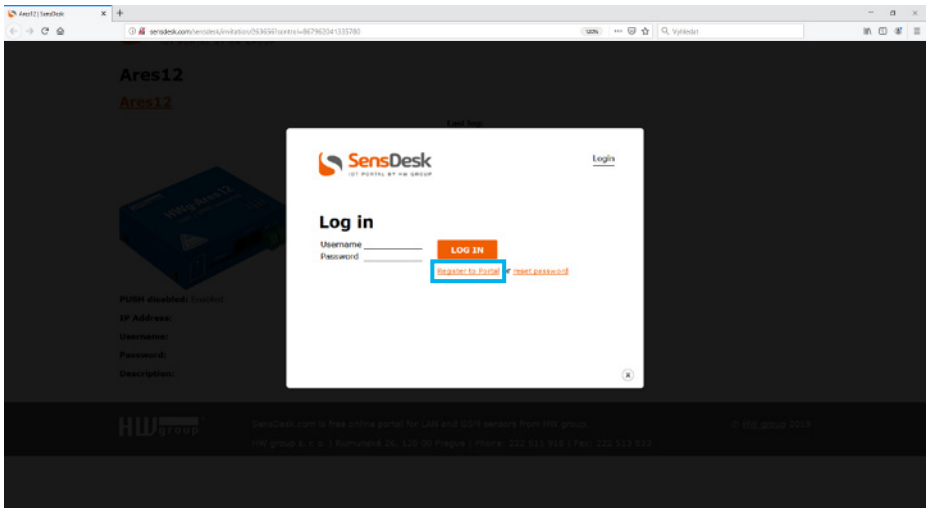

- 4 In case you already have a user account, please enter your login details and the device will be automatically assigned to your account. If you do not have a SensDesk account yet, click the *Register* and a registration form will be shown.

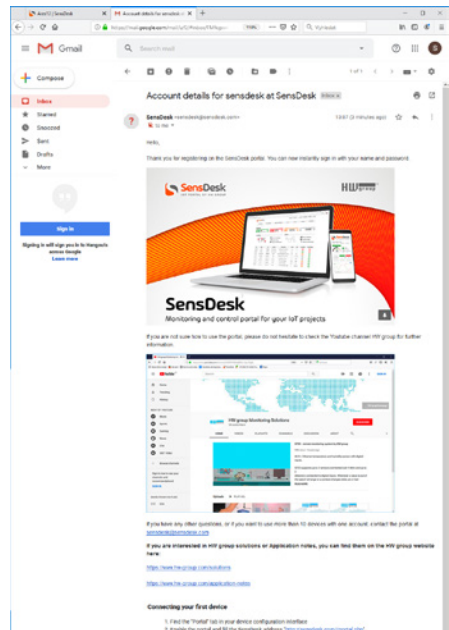
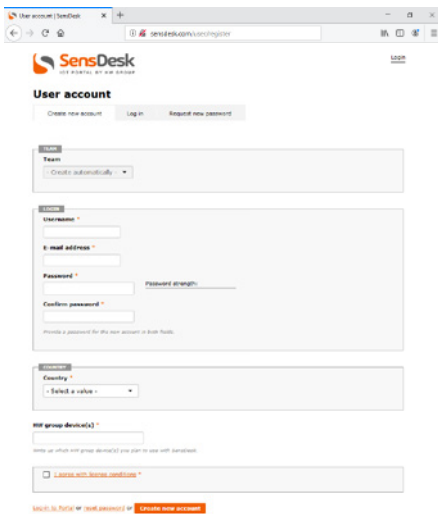

- 5 Enter the login details for your new account and a correct e-mail address. This e-mail address has to be unique for the server (cannot be already registered by another user).

The screenshot shows the SensDesk portal interface for a device named 'STE2'. At the top, there's a navigation bar with 'Login: demo', 'My account', 'Help', 'License', and 'Log out'. Below that, a secondary navigation bar contains tabs for 'Dashboards', 'Devices', 'Sensors', 'Locations', 'Device groups', 'Graphs', and 'Settings'. The main content area features a 'Home' breadcrumb and a 'STE2' title. A device status card shows a green checkmark, 'Last log: 05.02.2020 15:22', and details for 'Device groups: Not assigned', 'Location: Not assigned', and 'IP Address: 185.186.250.49 port: 80'. To the right is an image of a white network device. Below this is a sensor gauge for 'Sensor\_38201' with a 'SAFE RANGE: 10 - 60' and a current reading of '27.8 °C'. At the bottom, there are two 'INPUTS' sections, 'Input 1' and 'Input 2', each with a green 'ON' button and a grey 'OFF' toggle switch.

- 6 By activating the account, you will be redirected to the *Devices > View* page. At this moment, the data-sending period is set to 10 seconds to show the sensors functionality. This page is active only for approximately 15 minutes after the activation, then the logging period changes to 15 minutes.

The screenshot shows the SensDesk portal interface for a team named 'Team HW group'. At the top, there's a navigation bar with 'Login: demo', 'My account', 'Help', 'License', and 'Log out'. Below that, a secondary navigation bar contains tabs for 'Dashboards', 'Devices', 'Sensors', 'Locations', 'Device groups', 'Graphs', and 'Settings'. The main content area features a 'Home > Settings > Teams' breadcrumb and a 'Team HW group' title. A device status card shows buttons for 'View', 'Edit', 'values.xml', and 'List', along with a 'BUY PREMIUM' button. Below this are two sections: 'PUSH' and 'LIMITS'. The 'PUSH' section shows 'Team: demo' and 'Team password: demo'. The 'LIMITS' section shows 'Date of expiration:' and usage statistics for 'Dashboard limit: 3 Used 1', 'Device limit: 20 Used 18', and 'Graph limit: 3 Used 2'.

- 7 If you check *Teams* link, you will find your *Team Password*. This password, together with your login name, identifies the device in communication with your account and in communication of mobile applications with SensDesk. The password cannot be changed and for a security reason it is different to the login password.

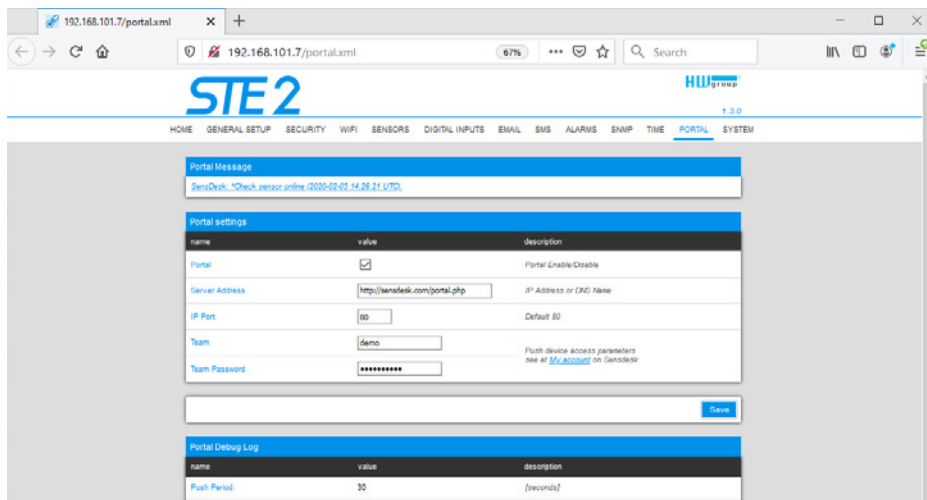

- 8 *Team Password* can be used in devices to skip the logging procedure during assigning the device to your portal account, or in mobile applications:

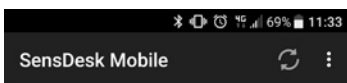

Sort by DEVICES		
ALL	ALARMS	
Ares12 Online Prague	100 %	Battery Monitor
Ares12 Online Prague	83 %	Bright in box
Ares12 Online Prague	1	External Power
Ares12 Online Prague	55 Pulses	External Power (Counter)
Ares12 Online Prague	0	Input 1
Ares12 Online Prague	5 Pulses	Input 1 (Counter)
Ares12 Online Prague	0	Input 2
Ares12 Online Prague	1 Pulses	Input 2 (Counter)
Ares12 Online Prague	31.2 %RH	Outdoor RH
Ares12 Online Prague	16.087 °C	Outdoor Temp.

*Portal* function periodically sends the data to a remote server and the sending period is set by this server.

*AutoPush* is a function allowing unusual measured data sending, beside the periodical logging, in case that the value change is higher than the *AutoPush* delta parameter.

## Using the mobile phone app

The **Username** and **PUSH Device** password can also be used in the application settings on mobile phones.

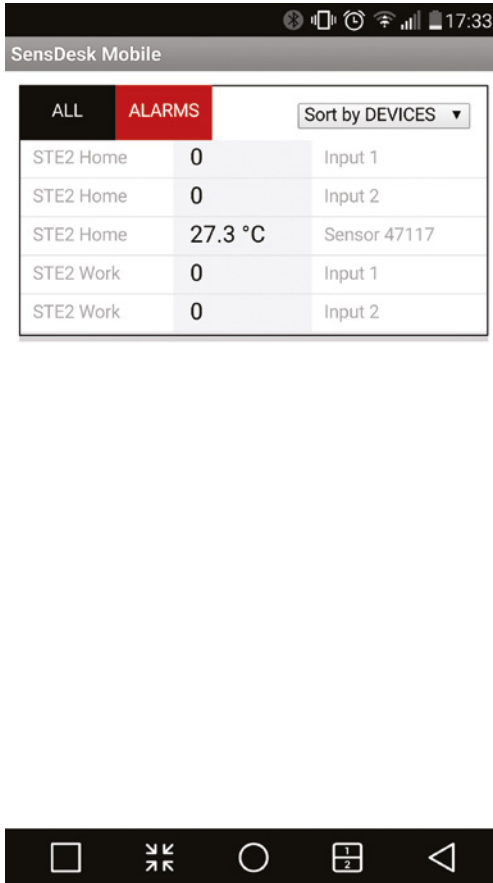

The screenshot shows the SensDesk Mobile app interface. At the top, there is a status bar with various icons and the time 17:33. Below the status bar, the app title "SensDesk Mobile" is displayed. The main content area features a table with columns for location, alarm count, and device name. The "ALARMS" tab is selected, and the data is sorted by "DEVICES".

ALL	ALARMS	Sort by DEVICES ▾
STE2 Home	0	Input 1
STE2 Home	0	Input 2
STE2 Home	27.3 °C	Sensor 47117
STE2 Work	0	Input 1
STE2 Work	0	Input 2

At the bottom of the screen, there is a navigation bar with five icons: a square, a starburst, a circle, a square with a smaller square inside, and a triangle pointing left.

# Firmware upgrade in STE2 units

- 1 Open the device web interface in the *System* tab.

The screenshot shows the STE2 web interface with the 'SYSTEM' tab selected. The 'Download' section contains a table of links for various configuration files. The 'Systems' section displays system information for a STE2 Rev2 unit, including serial number, MAC addresses, version, and uptime. A 'Network Upgrade' section is highlighted with a blue box, showing 'Read available version...' and 'Start Network Upgrade...' links.

Description	file
Backup configuration	<a href="#">STE2_Rev2_Config.zip</a>
Online setup in XML	<a href="#">setup.xml</a>
Online version in XML	<a href="#">info.xml</a>
SNMP MIB Table	<a href="#">STE2_Rev2.mib</a>
OD keys table	<a href="#">Online_OD_keys.tbl</a>
TXT list of common SNMP OIDs	<a href="#">STE2_Rev2_OCID.txt</a>

name	value
Product Name	STE2 Rev2
Serial Number	600966635
Eth MAC Address	00 8A 59 84 F8 2B
WiFi STA MAC Address	00 8A 59 84 F8 2D
Version	1.3.0
Fluck	349
Compile time	Nov 27 2019, 21:20:45
Up Time	22473 [s]
Device Mode	<a href="#">Device Mode</a>
Network Upgrade	<a href="#">Read available version...</a> <a href="#">Start Network Upgrade...</a>

Upload Firmware or Configuration:  no file selected.

- 2 The *System* section contains items to identify and download the current FW version.

This screenshot is identical to the one above, but with a blue rectangular box highlighting the 'Network Upgrade' section in the 'Systems' table. The highlighted section contains the links 'Read available version...' and 'Start Network Upgrade...'.



- 3 **Read available version** – Serves to identify and display the current firmware version on the update server. Click on the **Read available version** link.

System	
name	value
Product Name:	STE2 Rev2
Serial Number:	6006990035
Eth MAC Address:	00:0A:59:04:F8:2B
Wifi STA MAC Address:	00:0A:59:04:F8:2D
Version:	1.3.0
Build:	349
Compile time:	Nov 27 2019, 21:28:46
Up Time:	22473 [s]
Demo Mode:	<a href="#">Demo Mode</a>
Network Upgrade	<a href="#">Read available version</a> --- <a href="#">Start Network Upgrade</a> ---
Upload Firmware or Configuration:	<input type="button" value="Browse..."/> No file selected. <input type="button" value="Upload"/> <input type="text"/>

- 4 **Start Network Upgrade** – Serves to upgrade firmware to the device. The download progress is displayed while upgrading. Click on the **Start Network Upgrade** link.

System	
name	value
Product Name:	STE2 Rev2
Serial Number:	6006990035
Eth MAC Address:	00:0A:59:04:F8:2B
Wifi STA MAC Address:	00:0A:59:04:F8:2D
Version:	1.3.0
Build:	349
Compile time:	Nov 27 2019, 21:28:46
Up Time:	22473 [s]
Demo Mode:	<a href="#">Demo Mode</a>
Network Upgrade	<a href="#">Read available version</a> --- <a href="#">Start Network Upgrade</a> ---
Upload Firmware or Configuration:	<input type="button" value="Browse..."/> No file selected. <input type="button" value="Upload"/> <input type="text"/>

5

After the upgrade, the user is requested to restart the device manually.

System	
name	value
Product Name:	STE2 Rev2
Serial Number:	6006990035
Eth MAC Address:	00:0A:59:04:F8:2B
Wifi STA MAC Address:	00:0A:59:04:F8:2D
Version:	1.3.0
Build:	349
Compile time:	Nov 27 2019, 21:28:46
Up Time:	22473 [s]
Demo Mode:	<a href="#">Demo Mode</a>
	<a href="#">Read available version</a> ---
Network Upgrade	<a href="#">Start Network Upgrade</a> ---
Upload Firmware or Configuration:	<input type="button" value="Browse..."/> No file selected. <input type="button" value="Upload"/> <input type="text"/>

To do this, press the [Restart](#) button. **The device will not restart automatically and this must be done manually.**

Check the firmware version after restart.

System	
name	value
Product Name:	STE2 Rev2
Serial Number:	6006990035
Eth MAC Address:	00:0A:59:04:F8:2B
Wifi STA MAC Address:	00:0A:59:04:F8:2D
Version:	1.3.0
Build:	349
Compile time:	Nov 27 2019, 21:28:46
Up Time:	22473 [s]
Demo Mode:	<a href="#">Demo Mode</a>
	<a href="#">Read available version</a> ---
Network Upgrade	<a href="#">Start Network Upgrade</a> ---
Upload Firmware or Configuration:	<input type="button" value="Browse..."/> No file selected. <input type="button" value="Upload"/> <input type="text"/>





HW group s.r.o.  
Rumunská 26/122  
Prague, 120 00  
Czech Republic

Phone: +420 222 511 918  
Fax: +420 222 513 833

[www.HW-group.com](http://www.HW-group.com)